

INVESTMENT PRESENTATION

NOVEMBER 2020

OTC MARKETS – CANOF
TSX VENTURE – CNO.V





Forward-Looking Statements

This California Nanotechnologies Inc. (“Cal Nano” or the “Company”) presentation contains certain statements, which may constitute “forward looking information” under Canadian securities law requirements and “forward looking statements” under applicable securities laws (“forward-looking information”). All statements other than statements of historical fact contained in this presentation, including, but not limited to, statements with respect to the future financial positions and results of operations, strategy, plans, objectives, goals and targets and words and expressions of similar. Forward-looking information is based on the reasonable assumptions, estimates, analysis and opinions of management made in light of its experience and perception of trends, current conditions and expected developments, as well as other factors that management believes to be relevant and reasonable at the date that such statements are made.

Forward-looking information involves known and unknown risks and uncertainties and other factors which may cause the actual results, performance or achievements of Cal Nano to be materially different from any future results, performance or achievements expressed or implied by such forward-looking information. These factors include, the ability of Cal Nano to operate as a going concern; development and operating risks; the Company’s limited operating history; the trading price and volatility of the Company’s common shares; global financial volatility; and reliance on key members of management.

Forward-looking information is based on assumptions that Cal Nano believes to be reasonable. Key assumptions upon which the Company’s forward-looking information is based include, but are not limited to: that the Company will have sufficient working capital and be able to secure additional funding necessary for continued operation of the Company’s interests; and that the key personnel will continue their employment with the Company.

Forward-looking information in this presentation includes expectations relating to: the pipeline for future acquisitions which may be impacted by Cal Nano’s ability to negotiate suitable terms, due diligence, access to capital and market conditions; and availability of capital which may be impacted by the results of the offering, capital market and borrowing conditions.

Although the Company has attempted to identify important factors that could cause actual actions, events or results to differ materially from those described in forward-looking information, there may be other factors that cause actions, events or results not to be as anticipated, estimated or intended. There can be no assurance that forward-looking information will prove to be accurate, as actual results and future events could differ materially from those anticipated in such statements. Accordingly, readers should not place undue reliance on forward looking information. The Company undertakes no obligation to publicly update or revise any forward-looking information, whether as a result of new information, future events or otherwise, other than where a duty to update such information or provide further disclosure is imposed by applicable law.

To become a global leader in Spark Plasma Sintering and Cryogenic Milling advanced research and production. Develop, produce, and exceed demanding industry expectations while enhancing shareholder value.



- **Develop and lead the deployment of Spark Plasma Sintering and Cryogenic Milling for large multi-national corporations and national laboratories**
- **Sell and install Spark Plasma Sintering and Cryogenic Milling systems**
- **Provide support, expertise, maintenance and consumables for all system installations**
- **Cutting edge research into advanced metallic alloys & ceramic materials for unique and high-value applications**
- **Transitioning SPS and Cryogenic Milling Technologies from R&D to production for sustained profitability while increasing share holder value**

Looking back, Sales by Year (yr end Feb 28)

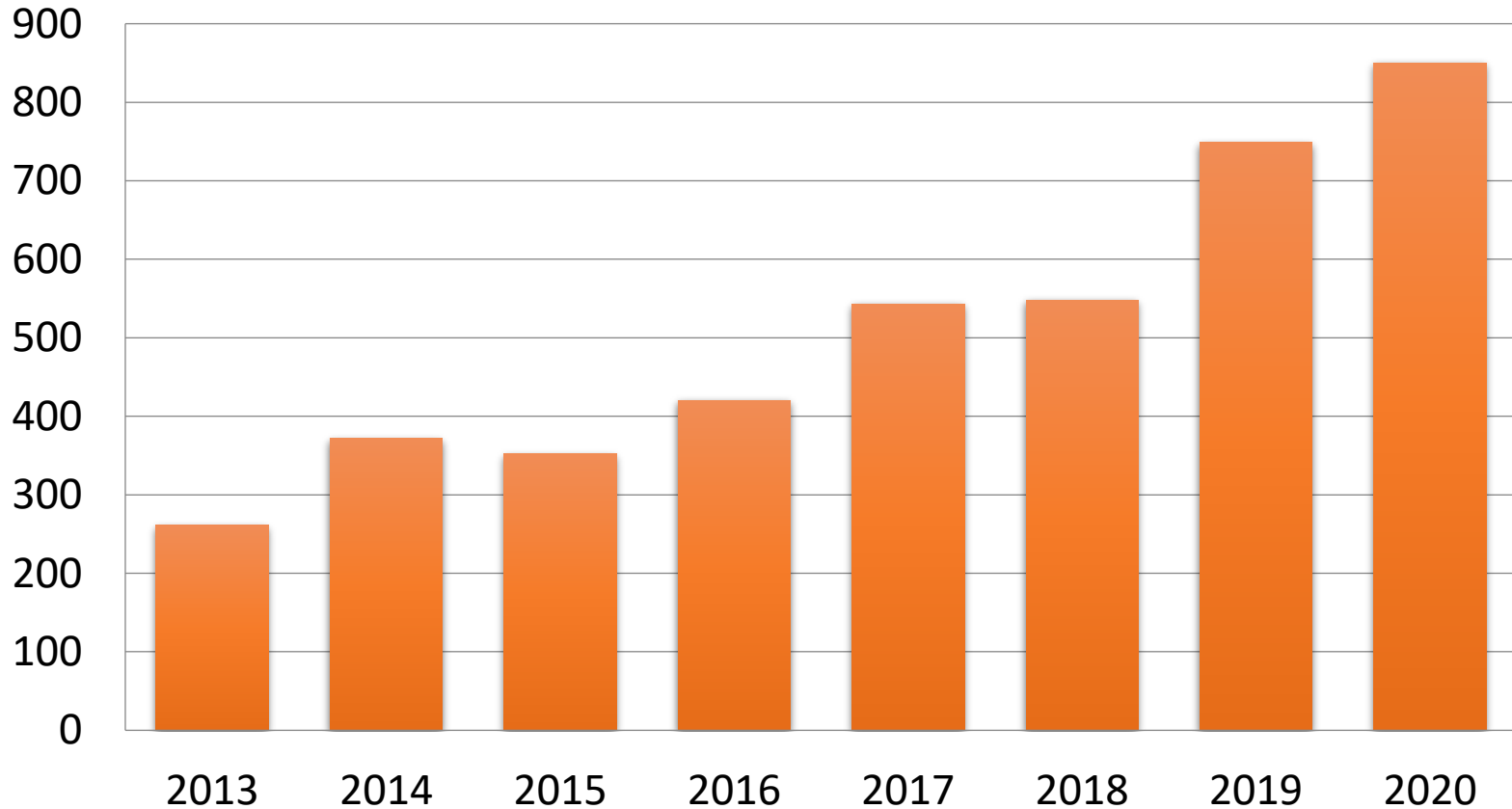

Continuous growth, for the past 6 years, with additional large OEM accounts being added for various markets

Cal Nano is the only company in North America offering toll services for both **Spark Plasma Sintering (SPS)** and **Cryogenic Milling (CM)**

These technologies, for which we have been pioneers in the industry, have slowly been growing and have been accepted as the next frontier in developing & manufacturing the next generation of advanced materials/products. Due to our leadership in SPS and CM, we are the forefront of this technology for mass production.

SPS and CM allow the creation of new products with unique metallurgical properties that can increase strength, reduce weight and create new functionality for metals such as High Entropy Alloys, Titanium, Nano Metal Matrix Composites (MMC) and more.

Cal Nano has developed advanced materials/components for the nuclear, semiconductor, aerospace and sports & recreation industry

Large Scale R&D – In collaboration with a key partner in the nuclear industry, Cal Nano cryomilled, SPS'd, & analyzed dozens of new advanced powder systems for next-gen nuclear materials



Innovative Solutions - Cal Nano's engineering team developed a complicated component with internal features via SPS for a multi-national semiconductor company

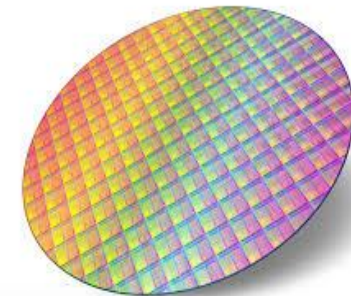

Commercialization - The successful commercialization of the adiZero prime SP track spike has paved the path for future “powder to part” nano-engineered components

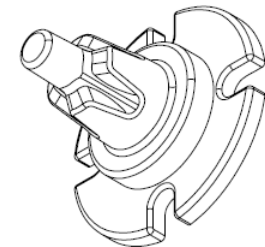

SPS is the fastest way to repeatedly densify or consolidate nano-structured and advanced materials

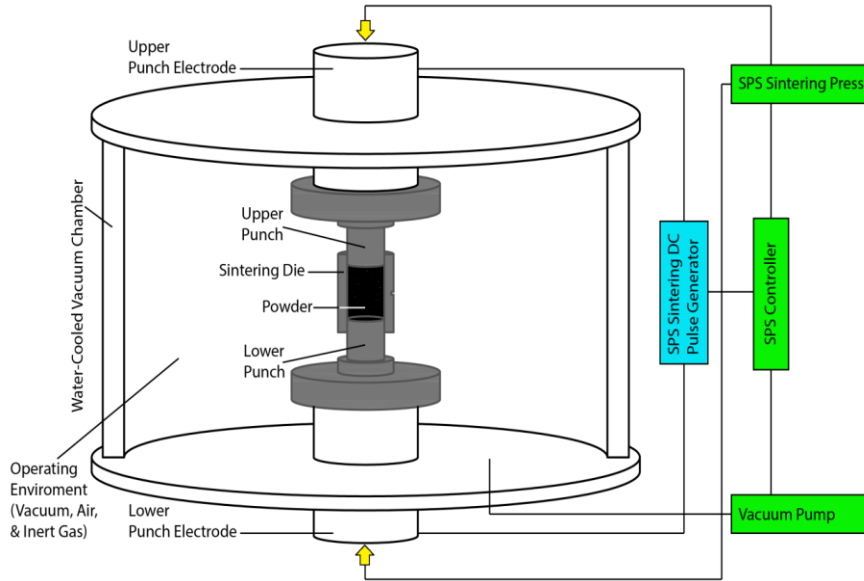

SPS Applications:

- Semiconductors
- Fine Ceramics
- Thermoelectrics
- Functionally Graded Materials
- Electronics
- Nanophases
- Hard Alloy Tools
- Diamond Tools
- Biomaterials
- Porous Materials
- Molds and Dies

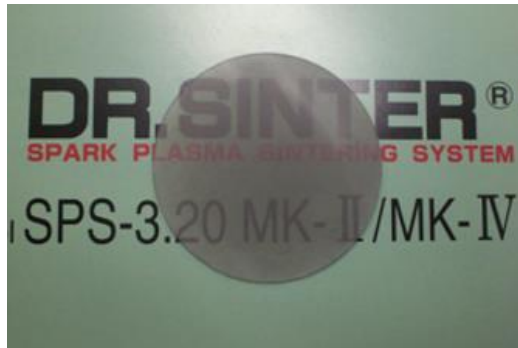

Transparent ceramics

a) Target post sintering geometry

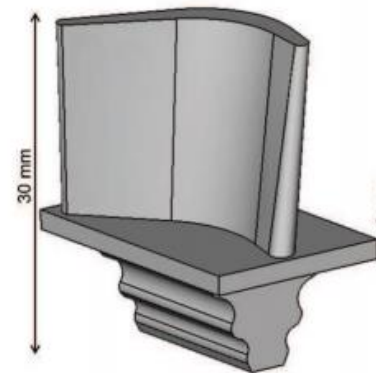

b) Spark plasma sintered turbine blade



SPS-515



- Specs - 1500 A/50 kN
- Max- ~ 1.5" diameter samples
- Has been used for R&D at Cal Nano for 10 years
- Over 10,000 SPS runs performed
- Vacuum/N/Ar atmosphere

SPS 7.40 Mk IV



- Specs - 10000 A/1000 kN
- Max- ~7" diameter samples
- Installed in Fall 2017 for larger R&D and pilot scale SPS programs
- Vacuum/N/Ar atmosphere

Cal Nano is the exclusive North American Technical & sales partner of the SPS equipment Manufacturer, SUGA.

Cal Nano performs all installations, training and servicing of Spark Plasma Sintering equipment sold by SUGA in North America and receives a 5% commission for all sales. Equipment prices can range from \$100k to \$1 MM+.

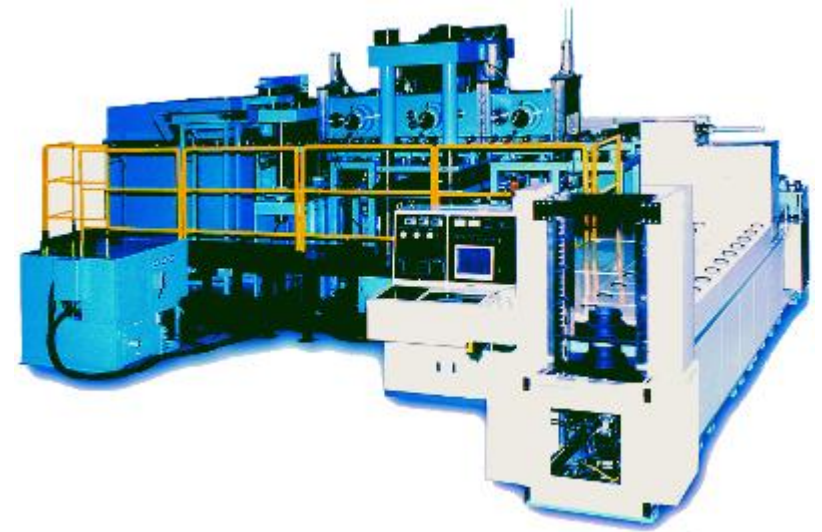

Fully Automated Production SPS System

Transition from R&D to Production - SPS Production Capabilities

Tunnel-type Automatic SPS Manufacturing systems (Installed in 2001 in Japan)

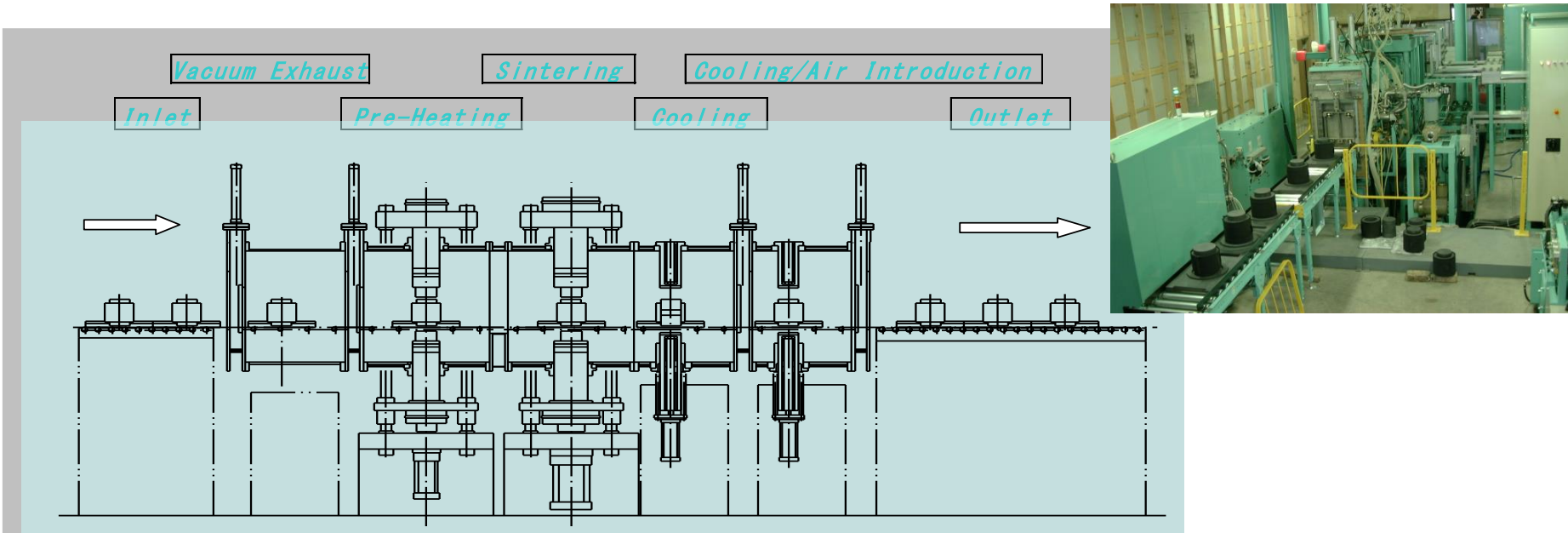

Using an automated tunnel-type system, SPS is capable of manufacturing high volumes of parts.

Example of Industrial Application – High Temperature Disc Brake

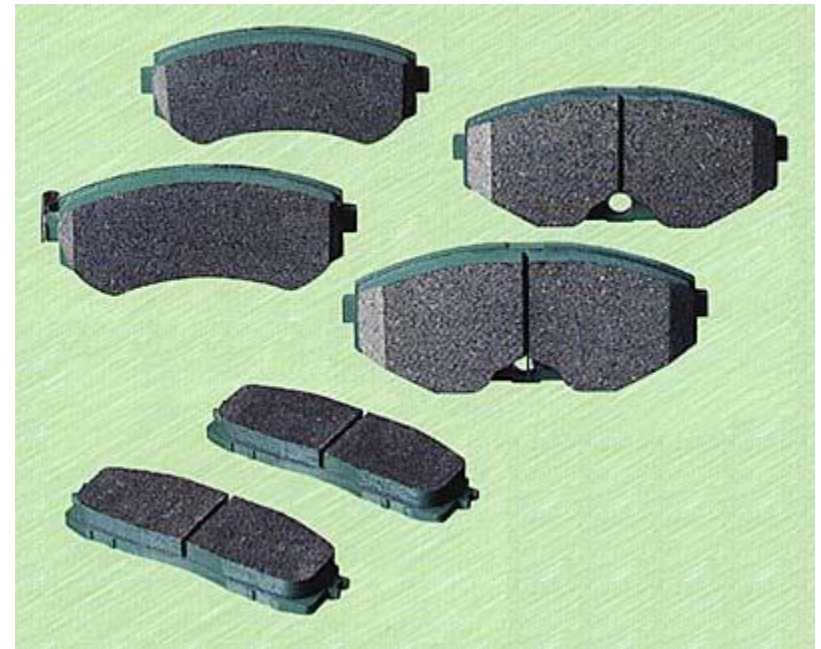
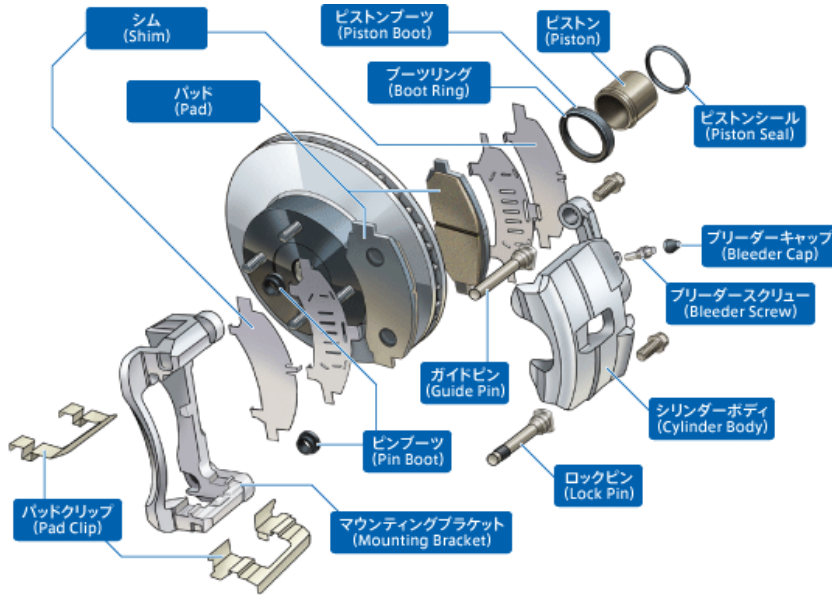

**High Performance Brake
For Motor Sports
For Bullet Train**

Example of Industrial Application – 3D Net Shape for Biomedical Application



Cryogenic Milling Capabilities

Cryogenic Milling is a specialized grinding process conducted in a liquid nitrogen environment of -200 C whereby metallic nano powders are created

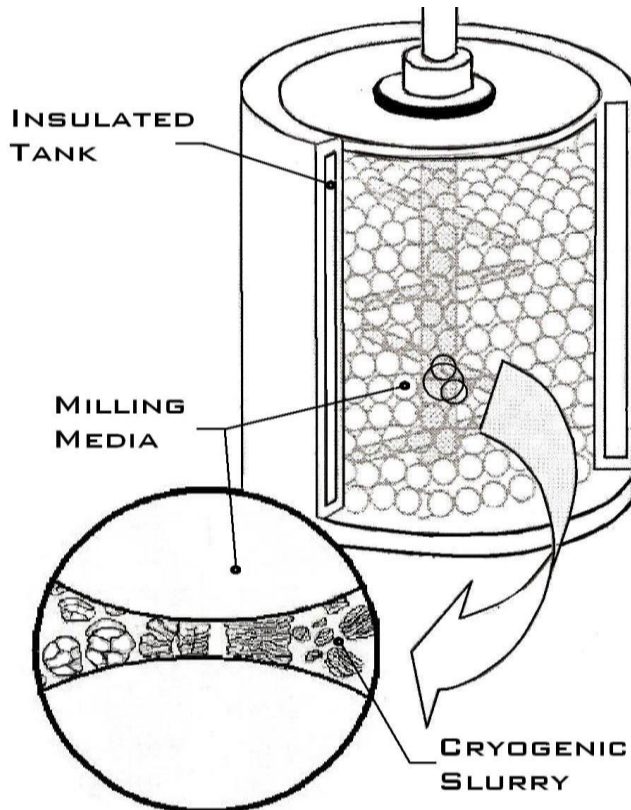

Three R&D and Pilot Scale Cryomills at our facility

- 500 gram powder capacity
- 1 kg powder capacity
- 7-10 kg powder capacity

Particle size reduction –

Ability to reduce polymer materials to Nanometer size which is typically not possible with other methods.

Strength Improvement –

Cal Nano was able to double standard Al 6061 tensile strength simply by cryomilling. No additives or heat treatment needed. Similar results have been achieved with Iron, Titanium and Nickel-based alloy systems.

Moisture/Oxygen Sensitive materials–

During our cryomilling process the material is fully submerged in cryogenic liquid at all times. Along with that, Cal Nano handles material pre and post-milled materials in an inert glove box making it a great process for sensitive materials.

Mechanical Alloying –

Cal Nano was able to produce high entropy alloy systems (mixing 5+ elements) safely and in about 1/5 the time compared standard milling processes

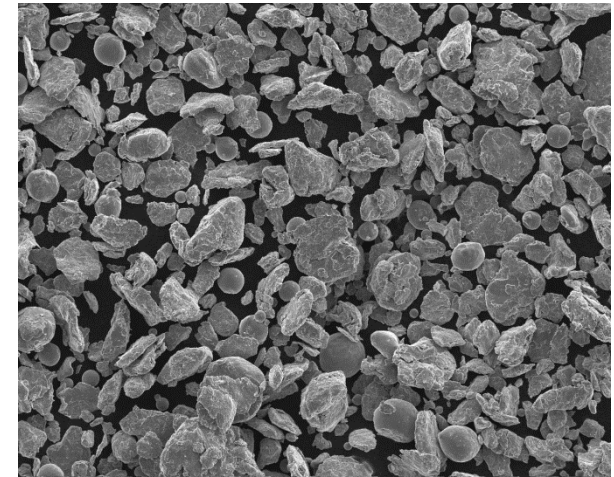

Transitioning from R&D to Production – Cryogenic Milling

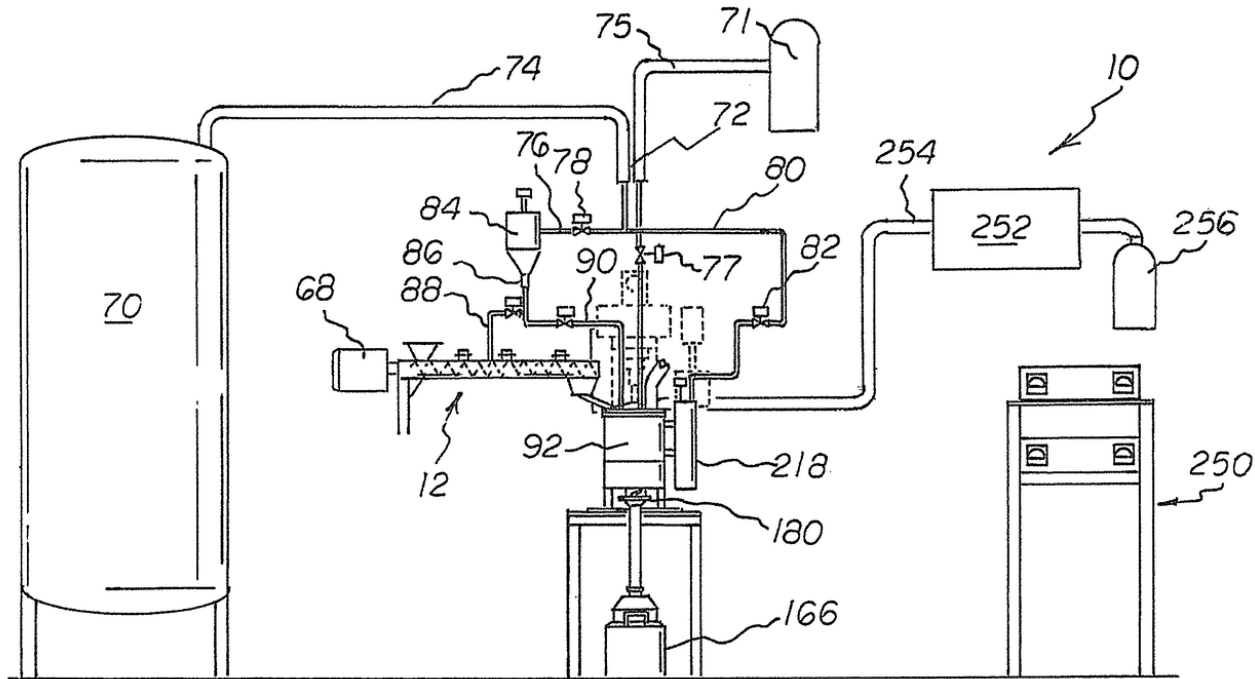

Cal Nano has received a patent submission securing key techniques allowing for safe and cost effective large scale commercial cryomilling. 100's to 10,000's of kg per week are achievable with cryomilling process.

- US Patent 9,943,854 B1 April 17, 2018



Cal Nano Financial Information

TSX Venture Exchange - CNO.V
OTCMKTS: CANOF

Shares Outstanding – 31.4 million
Recent Share Price – \$0.10 CAD
Market Value - \$3.14 MM CAD (~\$2.4 MM USD)

	FY2019	FY2020	FY2021 YTD (6 months)
Revenue	\$749,793	\$831,052	\$445,305
EBITDA	\$138,416	\$141,122	\$40,315
Net Income	(\$59,167)	(\$56,089)	(\$53,871)



Cal Nano Contact Information

For further information, please contact:

Eric Eyerman, CEO

T: (562)-991-5211

E: info@calnanocorp.com

W: www.calnanocorp.com

Except for historical information contained herein this document contains forward-looking statements. These statements contain known and unknown risks and uncertainties that may cause the Company's actual results or outcomes to be materially different from those anticipated and discussed herein.